

Danly manufacture custom die sets on the latest generation CNC machining centres.

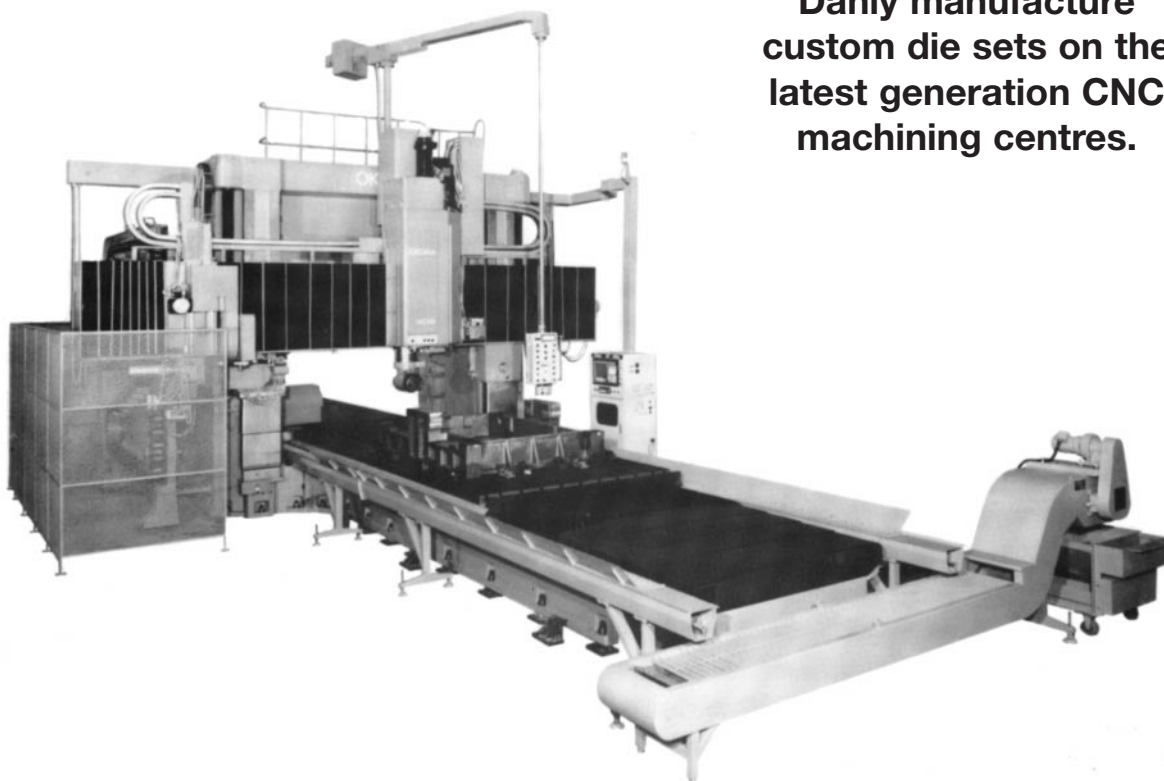

Two factors produce the high accuracy of Danly die sets. The high precision of our components and our system of selective fit which provides the uniform pillar to bush clearance in each guiding unit of the die set. The following classes of fit are available:

Class 1:

Clearance between punch and die sections is no more than 0,018mm per side; for carbide dies, lamination dies, and dies for very thin materials.

Class 2:

Clearance between punch and die sections from 0,02 to 0,06mm per side; for precision dies using stock thicker than 0,4mm.

Class 3:

Clearance between punch and die sections of 0,08mm per side; for automotive, hardware forming, or draw dies.

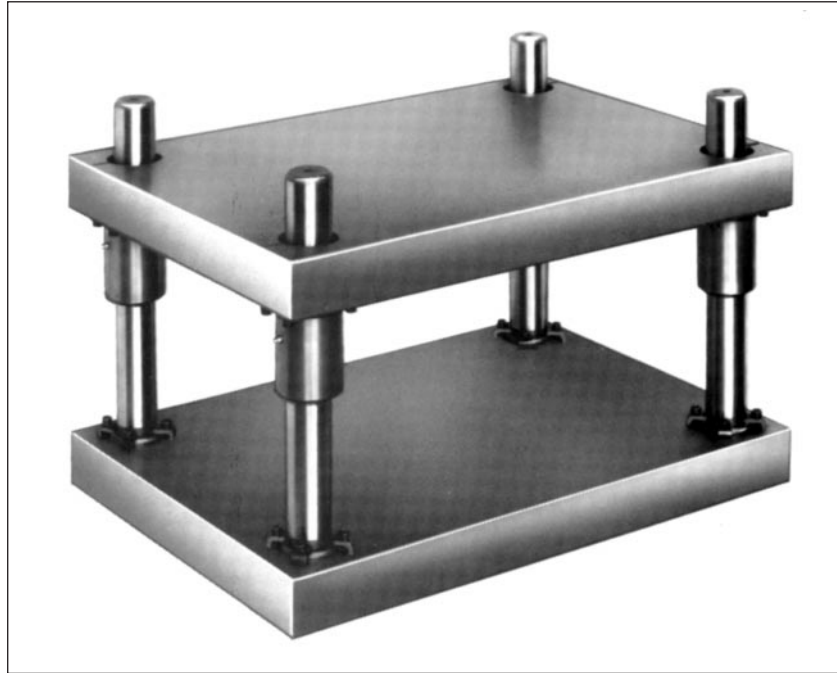

Demountable guide pillars and bushes are easily removed for die construction and maintenance. Worn or damaged guide pillars and bushes can easily be replaced, because all Danly guide elements are completely interchangeable.

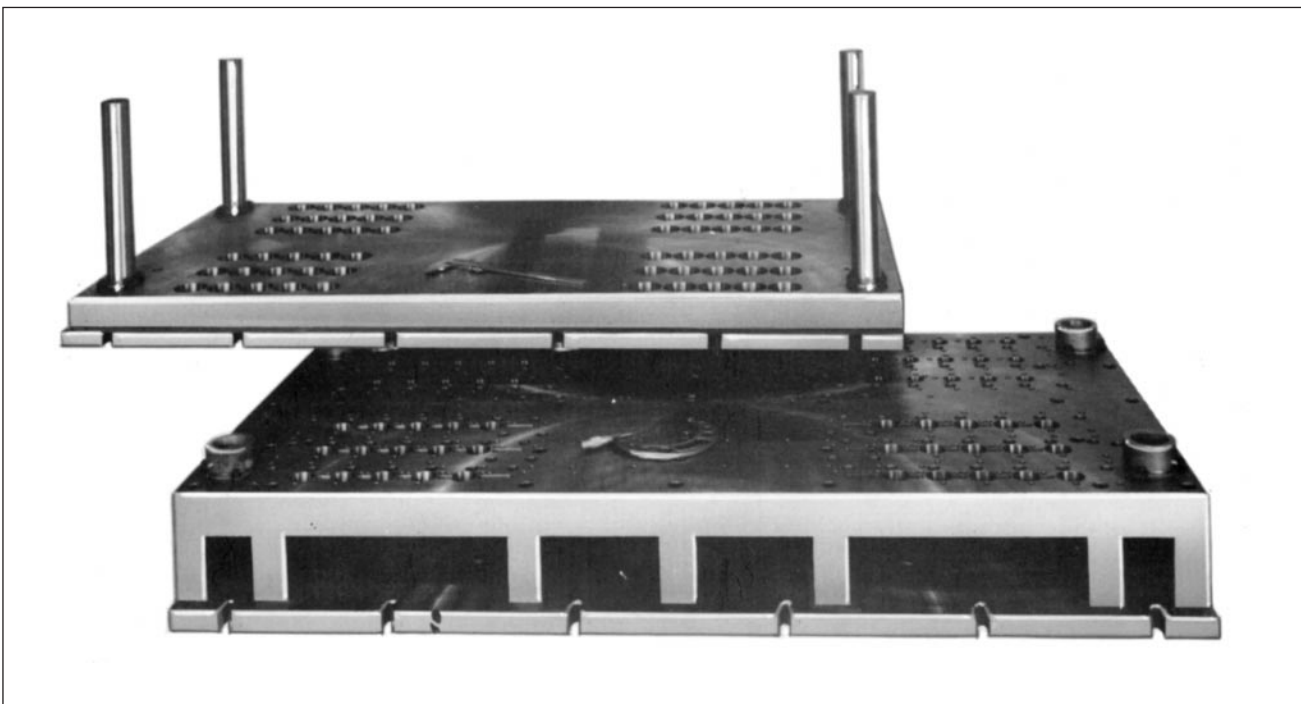

In order to help you choose an effective die set design, the charts on the next eight pages list our suggested minimum plate thicknesses and guide pillar diameters.

MATERIALS AVAILABLE

(See page 3/12)
 BS EN 10 025 : 1990
 Grade Fe 430A
 BS 970 080A40
 Aluminium 7000 Series

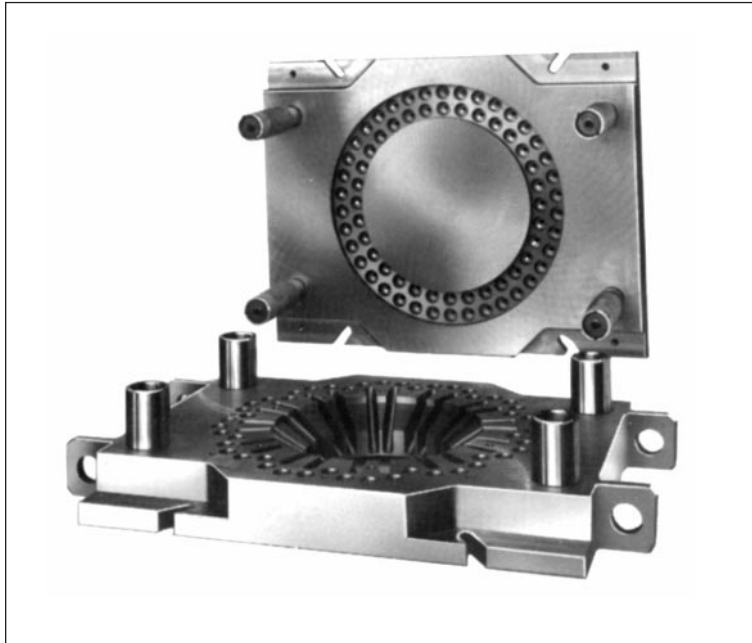

Danly will produce die sets according to your specific requirements. If you wish to make use of our extensive special machining services, simply furnish us with a drawing or CAD file with your order.

Die sets are machined on the latest generation of CNC machining centres for high accuracy and repeatability. There is virtually no limit to die set size.

Danly inventory grade Fe 430A steel up to 130mm thick, and with in-house flame cutting and grinding capability, profiles can be supplied in 1 to 2 working days, and ground plates in 2 to 3 working days.

Stress relieving and special machining may be supplied upon customer request.

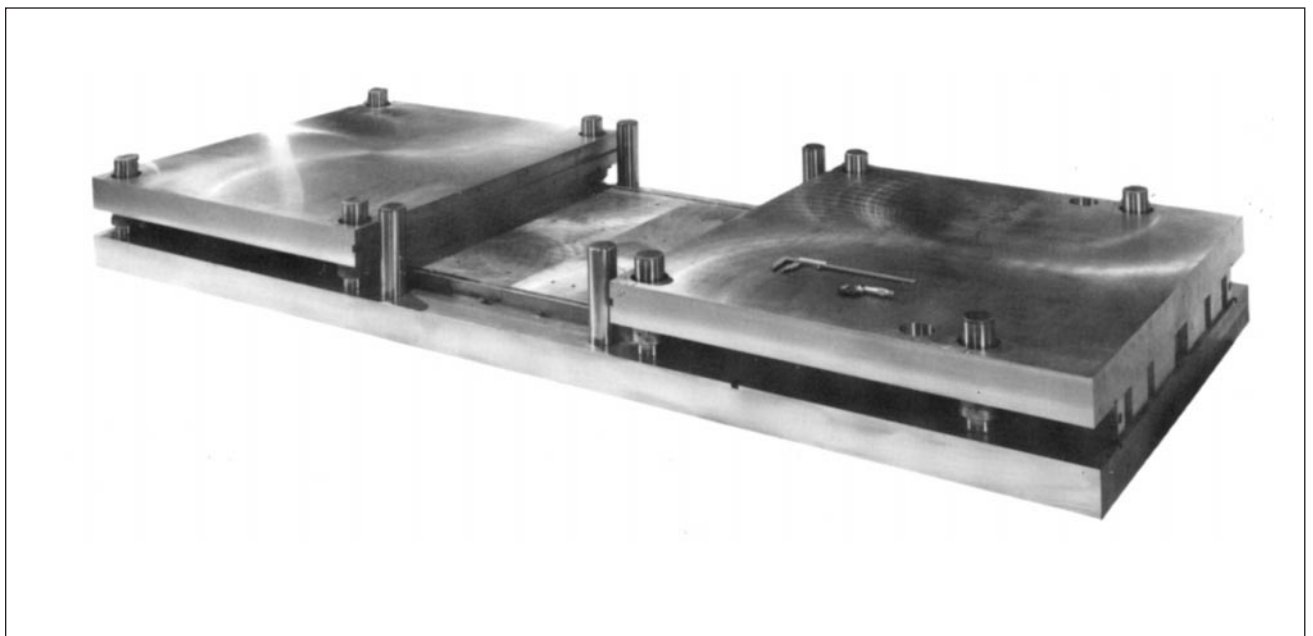
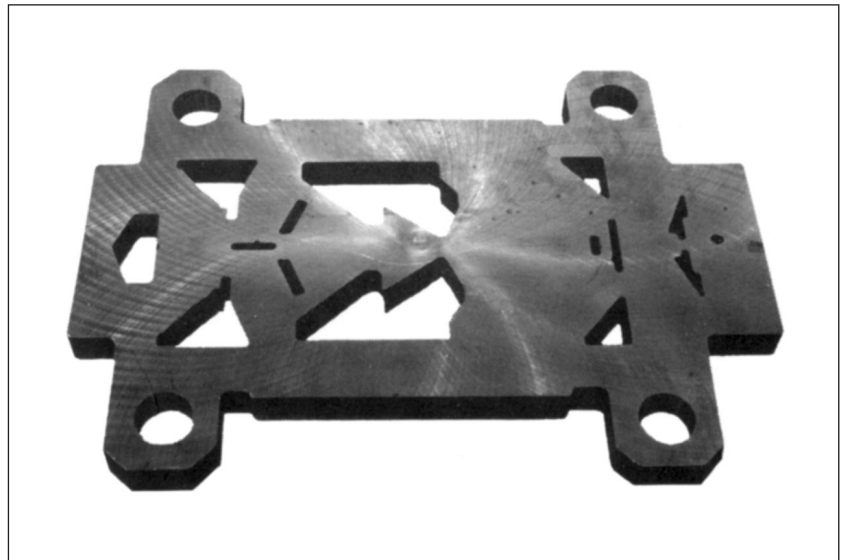

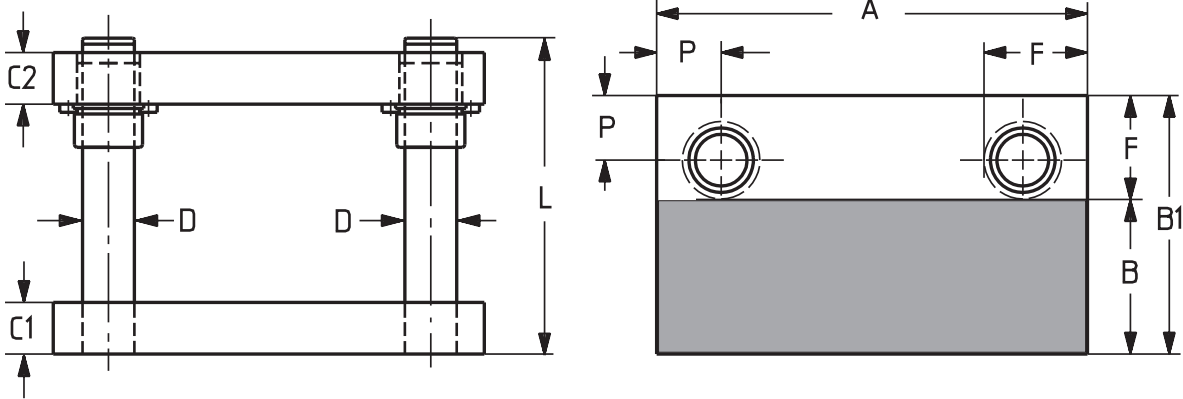

When the overall size of die set has been determined, our recommendations for minimum plate thickness and suggested diameters of guiding elements are indicated in the table below.

Note: These can be varied to suit customer requirements.

A	150-300	300-500	500-800	800-1500	1500-2000	2000-2500
C ₁	30	40	45	60	75	85
C ₂	25	35	40	50	55	55
D	25	32	40	50	63	80
F	61	72	84	97	113	133
P	39	45	54	59	68	78

ORDERING INFORMATION

When ordering please specify:

1. Series A-1.
2. Dimensions A and B.
3. Thicknesses C1 and C2, and thickness tolerance or clean up. C1 should be at least equal to guide pillar diameter D.
4. Guide pillar catalogue number.
5. Bush catalogue number.
6. Shank catalogue number and location.
7. Class of fit. Class 2 is assumed unless otherwise specified.

Above die sets can be fitted with pressed in or demountable pillars, together with demountable steel, sintered bronze or sinterlube bushes. See pages 4/2 - 4/5 for details.

MATERIALS AVAILABLE

(See page 3/12)
BS EN 10 025 : 1990
Grade Fe 430A
BS 970 080A40
Aluminium 7000 Series

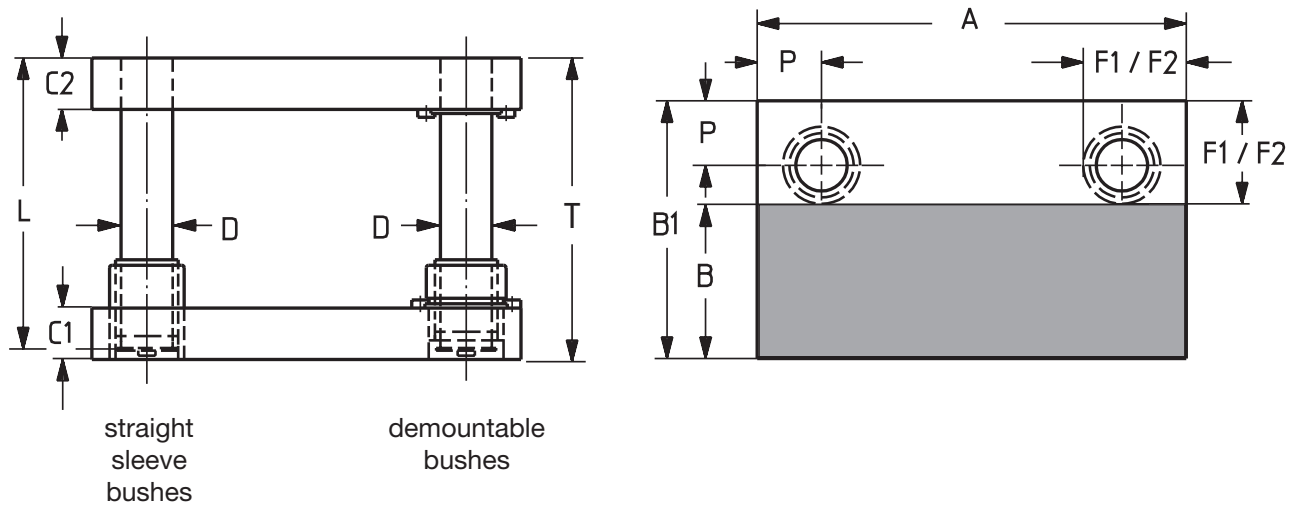

T= Minimum shut height of tool (die life depleted). See page 4/23

When the overall size of die set has been determined, our recommendations for minimum plate thickness and suggested diameters of guiding elements are indicated in the table below.

Note: These can be varied to suit customer requirements.

A	150-300	300-500	500-800	800-1500	1500-2000	2000-2500
C ₁	35	40	50	60	75	85
C ₂	25	35	40	50	60	80
D	25	32	40	50	63	80
F ₁	66.5	75	88.5	104.5	120.5	138
F ₂	69.5	78	92.5	109.5	125.5	
P	44	48	56	64	73	82

Note: USE F1 FOR SLEEVE BUSHES. F2 FOR DEMOUNTABLE.

ORDERING INFORMATION

When ordering please specify:

1. Series A-1BB.
2. Dimensions A and B.
3. Thicknesses C1 and C2 (C2 thickness should be at least equal to guide pillar diameter D).
4. Diameter and type of pillar, i.e. straight or demountable.
5. Type of bush, i.e. sleeve or demountable.
6. Maximum and minimum shutheight by specifying 'T' from bottom surface of die base to top surface of punch holder.
7. Stroke or ram movement of press.
8. Operating condition (Type 1 – Pre-loaded, Type II – Partial Pre-load and Relieving, Type III – Disengaging). See selection chart, pages 4/21 - 4/23.

Above die sets can be fitted with pressed in or demountable pillars, together with sleeve type or demountable bushes.
See pages 4/13 - 4/19 for details.

MATERIALS AVAILABLE

(See page 3/12)

BS EN 10 025 : 1990

Grade Fe 430A

BS 970 080A40

Aluminium 7000 Series

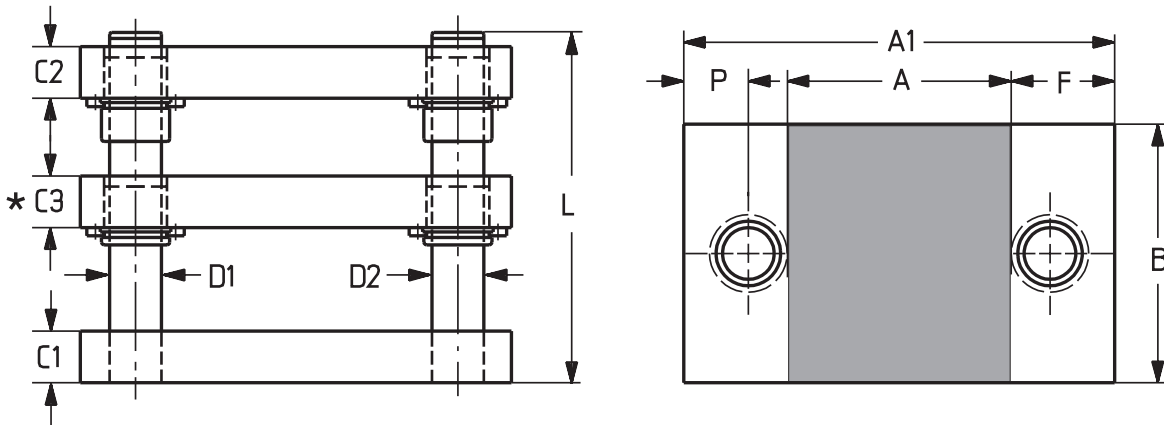

* C3 plate optional – if required, state thickness.

When the overall size of die set has been determined, our recommendations for minimum plate thickness and suggested diameters of guiding elements are indicated in the table below.

Note: These can be varied to suit customer requirements.

A	100-150	150-350	350-700	700-1400	1400-2000	2000-2500
C ₁	30	40	45	60	75	85
C ₂	30	35	40	50	55	55
D ₁	24	30	40	50	50	63
D ₂	25	32	42	52	63	80
F	61	72	84	97	113	133
P	39	45	54	59	68	78

ORDERING INFORMATION

When ordering please specify:

1. Series A-2.
2. Dimensions A and B.
3. Thicknesses C1 and C2, and thickness tolerance or clean up. C1 should be at least equal to guide pillar diameter D2.
4. Guide pillar catalogue number.
5. Bush catalogue number.
6. Shank catalogue number and location.
7. Class of fit. Class 2 is assumed unless otherwise specified.

Above die sets can be fitted with pressed in or demountable pillars, together with demountable steel, sintered bronze or sinterlube bushes. See pages 4/2 - 4/5 for details.

MATERIALS AVAILABLE

(See page 3/12)
BS EN 10 025 : 1990
Grade Fe 430A
BS 970 080A40
Aluminium 7000 Series

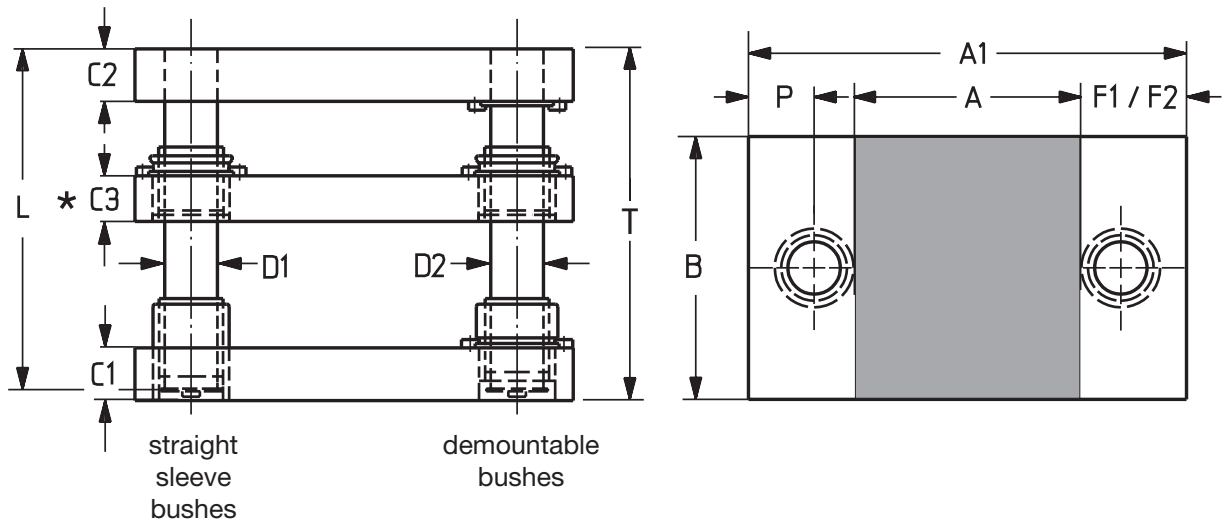

T = Minimum shut height of tool (die life depleted). See page 4/23.

* C3 plate optional – if required, state thickness.

When the overall size of die set has been determined, our recommendations for minimum plate thickness and suggested diameters of guiding elements are indicated in the table below.

Note: These can be varied to suit customer requirements.

A	100-300	300-700	700-1400	1400-2000	2000-2500
C ₁	40	50	55	65	80
C ₂	35	40	50	65	80
D ₁	25	32	40	50	63
D ₂	32	40	50	63	80
F ₁	75	88.5	104.5	120.5	138
F ₂	78	92.5	109.5	125.5	
P	48	56	64	73	82

Note: USE F1 FOR SLEEVE BUSHES. F2 FOR DEMOUNTABLE.

ORDERING INFORMATION

When ordering please specify:

1. Series A-2BB.
2. Dimensions A and B.
3. Thicknesses C₁ and C₂ (C₂ thickness should be at least equal to guide pillar diameter D₂).
4. Diameter and type of pillar, i.e. straight or demountable.
5. Type of bush, i.e. sleeve or demountable.
6. Maximum and minimum shutheight by specifying 'T' from bottom surface of die base to top surface of punch holder.
7. Stroke or ram movement of press.
8. Operating condition (Type 1 – Pre-loaded, Type II – Partial Pre-load and Relieving, Type III – Disengaging). See selection chart, pages 4/21 - 4/23.

Above die sets can be fitted with pressed in or demountable pillars, together with sleeve type or demountable bushes.
See pages 4/13 - 4/19 for details.

MATERIALS AVAILABLE

(See page 3/12)

BS EN 10 025 : 1990

Grade Fe 430A

BS 970 080A40

Aluminium 7000 Series

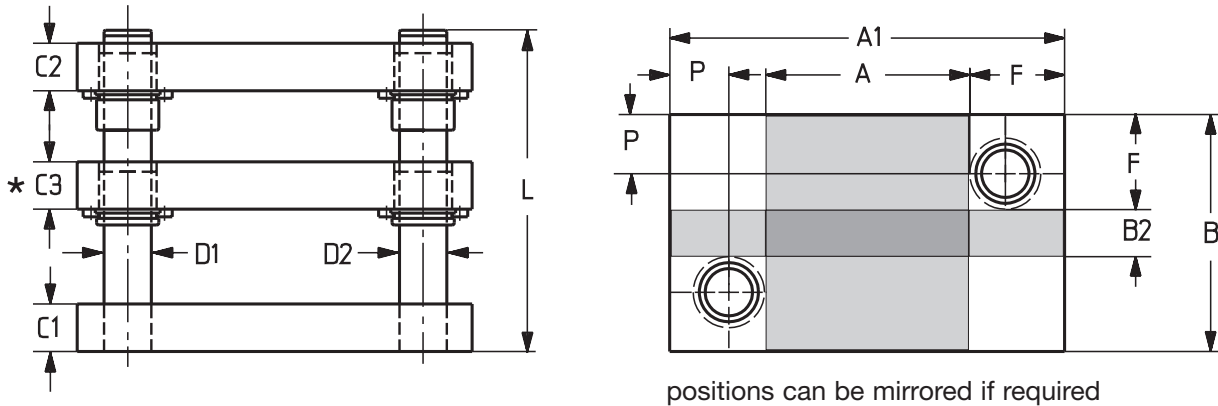

* C3 plate optional – if required, state thickness.

When the overall size of die set has been determined, our recommendations for minimum plate thickness and suggested diameters of guiding elements are indicated in the table below.

Note: These can be varied to suit customer requirements.

A	100-150	150-350	350-700	700-1400	1400-2000	2000-2500
C ₁	30	40	45	60	75	85
C ₂	30	35	40	50	55	55
D ₁	24	30	40	50	50	63
D ₂	25	32	42	52	63	80
F	61	72	84	97	113	133
P	39	45	54	59	68	78

ORDERING INFORMATION

When ordering please specify:

1. Series A-3.
2. Dimensions A and B.
3. Thicknesses C1 and C2, and thickness tolerance or clean up. C1 should be at least equal to guide pillar diameter D2.
4. Guide pillar catalogue number.
5. Bush catalogue number.
6. Shank catalogue number and location.
7. Class of fit. Class 2 is assumed unless otherwise specified.

Above die sets can be fitted with pressed in or demountable pillars, together with demountable steel, sintered bronze or sinterlube bushes. See pages 4/2 - 4/5 for details.

MATERIALS AVAILABLE

(See page 3/12)
BS EN 10 025 : 1990
Grade Fe 430A
BS 970 080A40
Aluminium 7000 Series

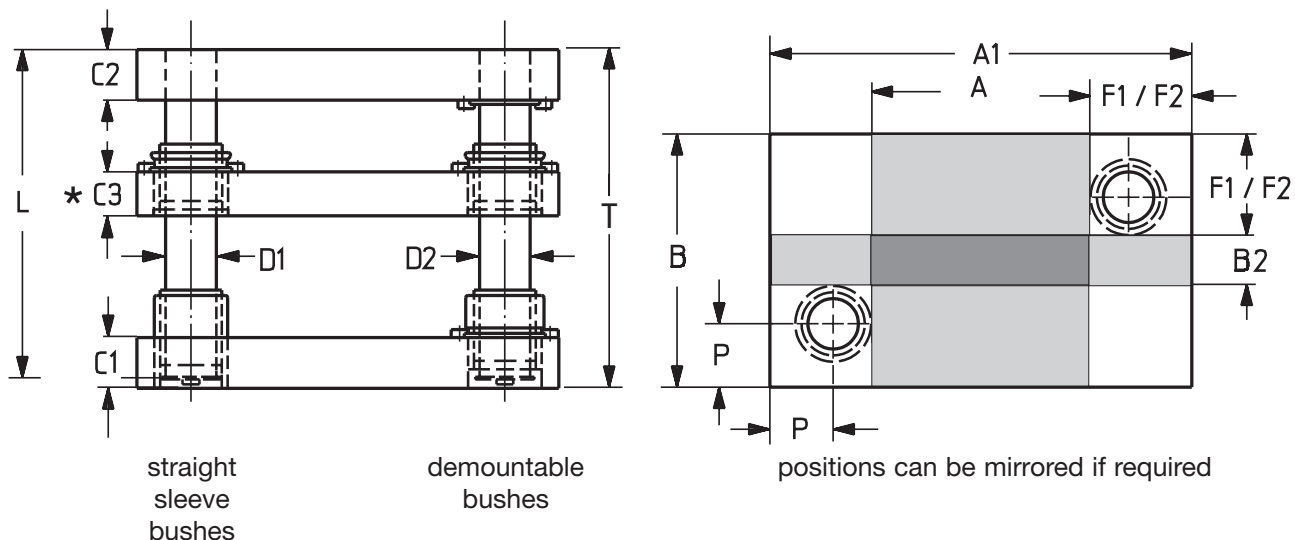

T = Minimum shut height of tool (die life depleted). See page 4/23.

* C3 plate optional – if required, state thickness.

When the overall size of die set has been determined, our recommendations for minimum plate thickness and suggested diameters of guiding elements are indicated in the table below.

Note: These can be varied to suit customer requirements.

A	100-300	300-700	700-1400	1400-2000	2000-2500
C ₁	40	50	55	65	80
C ₂	35	40	50	65	80
D ₁	25	32	40	50	63
D ₂	32	40	50	63	80
F ₁	75	88.5	104.5	120.5	138
F ₂	78	92.5	109.5	125.5	
P	48	56	64	73	82

Note: USE F1 FOR SLEEVE BUSHES. F2 FOR DEMOUNTABLE.

ORDERING INFORMATION

When ordering please specify:

1. Series A-3BB.
2. Dimensions A and B.
3. Thicknesses C1 and C2 (C2 thickness should be at least equal to guide pillar diameter D2).
4. Diameter and type of pillar, i.e. straight or demountable.
5. Type of bush, i.e. sleeve or demountable.
6. Maximum and minimum shutheight by specifying 'T' from bottom surface of die base to top surface of punch holder.
7. Stroke or ram movement of press.
8. Operating condition (Type 1 – Pre-loaded, Type II – Partial Pre-load and Relieving, Type III – Disengaging). See selection chart, pages 4/21 - 4/23.

Above die sets can be fitted with pressed in or demountable pillars, together with sleeve type or demountable bushes.
See pages 4/13 - 4/19 for details.

MATERIALS AVAILABLE

(See page 3/12)
BS EN 10 025 : 1990
Grade Fe 430A
BS 970 080A40
Aluminium 7000 Series

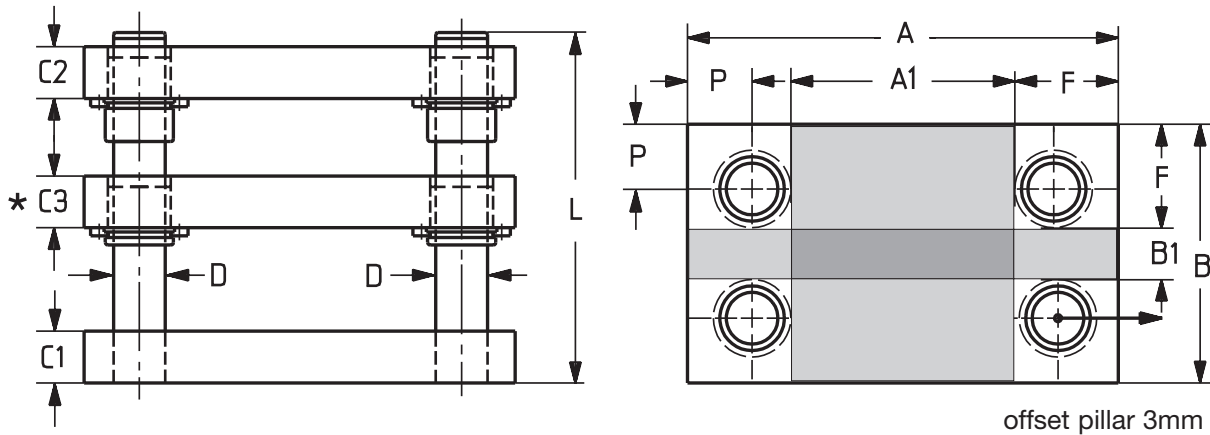

* C3 plate optional – if required, state thickness.

When the overall size of die set has been determined, our recommendations for minimum plate thickness and suggested diameters of guiding elements are indicated in the table below.

Note: These can be varied to suit customer requirements.

A	150-300	300-500	500-1000	1000-2000	2000-2500	2500-3000
C ₁	35	40	45	60	75	85
C ₂	25	35	40	50	50	55
D	25	32	40	50	63	80
F	61	72	84	97	113	133
P	39	45	54	59	68	78

ORDERING INFORMATION

When ordering please specify:

1. Series A-4.
2. Dimensions A and B.
3. Thicknesses C1 and C2, and thickness tolerance or clean up. C1 should be at least equal to guide pillar diameter D.
4. Guide pillar catalogue number.
5. Bush catalogue number.
6. Shank catalogue number and location.
7. Class of fit. Class 2 is assumed unless otherwise specified.

Above die sets can be fitted with pressed in or demountable pillars, together with demountable steel, sintered bronze or sinterlube bushes.
See pages 4/2 - 4/5 for details.

MATERIALS AVAILABLE

(See page 3/12)
BS EN 10 025 : 1990
Grade Fe 430A
BS 970 080A40
Aluminium 7000 Series

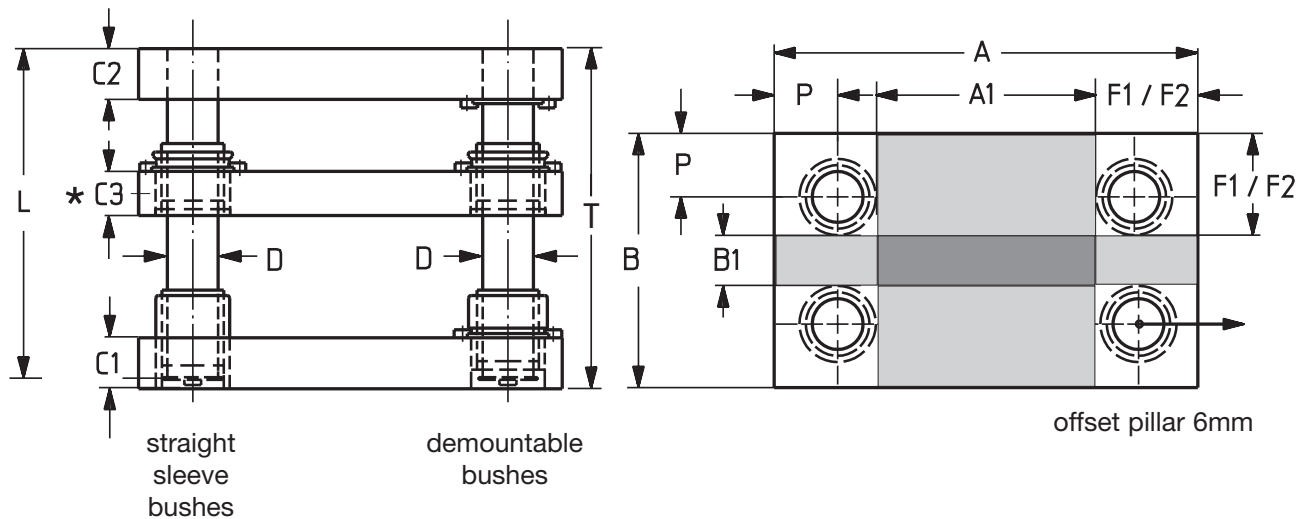

T = Minimum shut height of tool (die life depleted). See page 4/23.

* C3 plate optional – if required, state thickness.

When the overall size of die set has been determined, our recommendations for minimum plate thickness and suggested diameters of guiding elements are indicated in the table below.

Note: These can be varied to suit customer requirements.

A	150-300	300-500	500-1000	1000-2000	2000-2500	2500-3000
C ₁	35	40	50	60	75	85
C ₂	25	35	40	50	60	80
D	25	32	40	50	63	80
F ₁	66.5	75	88.5	104.5	120.5	138
F ₂	69.5	78	92.5	109.5	125.5	
P	44	48	56	64	73	82

Note: USE F1 FOR SLEEVE BUSHES. F2 FOR DEMOUNTABLE.

ORDERING INFORMATION

When ordering please specify:

1. Series A-4BB.
2. Dimensions A and B.
3. Thicknesses C1 and C2 (C2 thickness should be at least equal to guide pillar diameter D).
4. Diameter and type of pillar, i.e. straight or demountable.
5. Type of bush, i.e. sleeve or demountable.
6. Maximum and minimum shutheight by specifying 'T' from bottom surface of die base to top surface of punch holder.
7. Stroke or ram movement of press.
8. Operating condition (Type 1 – Pre-loaded, Type II – Partial Pre-load and Relieving, Type III – Disengaging). See selection chart, pages 4/21 - 4/23.

Above die sets can be fitted with pressed in or demountable pillars, together with sleeve type or demountable bushes.
See pages 4/13 - 4/19 for details.

MATERIALS AVAILABLE

(See page 3/12)

BS EN 10 025 : 1990

Grade Fe 430A

BS 970 080A40

Aluminium 7000 Series

As an additional service, Danly can supply steel plate in the grades listed below, and are suitable for a variety of industrial uses.

Plates can be ordered as raw material, or machined according to your needs.

BS EN 10 025 : 1990 Grade Fe 430 A				BS 970 Part 1 Grade 080A40	
CHEMICAL COMPOSITION					
C%	Max 0.25			C%	0.38 / 0.43
M%	Max 1.60			M%	0.70 / 0.90
Si%	Max 0.50			Si%	Max 0.40
P%	Max 0.050			P%	Max 0.050
S%	Max 0.050			S%	Max 0.050
RAW STOCK THICKNESSES (METRIC)					
6	52	150	450	6	65
8	55	165		8	70
10	60	180		10	75
12.5	65	200		12.5	80
15	70	215		15	85
20	75	230		20	90
25	80	250		25	95
30	85	260		30	100
32	90	280		32	110
35	95	305		35	115
38	100	330		40	120
40	110	360		45	130
42	115	380		50	260
45	120	405		55	
50	130	430		60	

Cut-outs required for blank holes, slug holes or slug chutes can be accommodated to your specification, to the tolerances listed below.

THICKNESS	HOLE SIZE	MIN HOLE SIZE PIERCE & PROFILE	MIN HOLE SIZE DRILL & PROFILE	HOLE LOCATION
6 - 30	+/-1.5	12 x 40	10 x 10	within 1.0
32 - 50	+/-2.0	15 x 40	10 x 15	within 1.0
52 - 75	+/-2.0	20 x 50	18 x 20	within 1.0
80 - 120	+/-3.0	25 x 50	20 x 20	within 2.0
130 - 200	+/-3.0	to be agreed	to be agreed	within 2.0
200+	+/-5.0	to be agreed	to be agreed	within 2.0

ORDERING INFORMATION

When ordering please specify:

1. Number of plates required.
2. Grade of steel.
3. Length, width and thickness.
4. Thickness clean-up or tolerance.
5. External or internal profile*.
6. Extra machining*.

(* = supply drawing)

Aluminium -v- Steel

Aluminium Die Sets, Machined Plates and Mould Plates.



REASONS TO USE ALUMINIUM OVER STEEL.

- One third the weight of steel.
- Faster and easier set up.
- Less wear and tear on machines and press bolsters.
- Better machinability means 20-35% increased feed rates.
- Machined with existing, conventional tooling.
- Draws heat away from tooling, then dissipates heat quickly.
- Superior corrosion resistance reduces maintenance costs.
- Impervious to typical (water soluble) die lubes.
- Non-magnetic – good environment for in die sensing.
- Strength levels equivalent to or greater than some steels means no loss in structural performance.
- Stress relieved in the process – a stable material before and after machining.
- Easily recyclable.

Note: For best results, it is recommended that any heavy machining is completed before surface grinding. We do not recommend using steel and aluminium plates in a die set combination, but please contact us for advice.

COMPARITIVE TECHNICAL DATA								
MATERIAL		PHYSICAL & MECHANICAL PROPERTIES						
		TENSILE STRENGTH Mpa	YIELD STRENGTH Mpa	DENSITY g/cm ³	THERMAL CONDUCTIVITY Wm/C	THERMAL EXPANSION 10-6/C	YOUNGS MODULUS Mpa	HARDNESS BRINELL
Steel Plate BS EN 10 025	Fe 430A	480	275	7.85	47	11.8	210,000	143
Aircraft Aluminium	Alumec 79	536	470	2.77	165	23.2	71,500	150
Aircraft Aluminium	Alumec 89	589	542	2.82	165	23.2	71,500	174
Aircraft Aluminium	Fortal HR-HS	540	540	2.80	121	23.6	72,000	145
Steel Plate BS 970 Part 1	O80A40	550	280	7.85	47	11.7	210,000	180